

DEPARTMENT OF MINERAL RESOURCES AND ENERGY

NO. 326

9 April 2021

MINE HEALTH AND SAFETY ACT, 1996 (ACT NO 29 OF 1996)**GUIDELINE FOR THE COMPILATION OF A MANDATORY CODE OF PRACTICE FOR THE PREVENTION OF FLAMMABLE GAS EXPLOSIONS IN MINES OTHER THAN COAL MINES**

I, **MR. DAVID MSIZA**, Chief Inspector of Mines, under section 49 (6) of the Mine Health and Safety Act, 1996 (Act No. 29 of 1996) and after consultation with the Mine Health and Safety Council, hereby issue the Guideline for the Compilation of a Mandatory Code of Practice for the Prevention of Flammable Gas Explosions in Mines other than Coal Mines in terms of the Mine Health and Safety Act, as set out in the Schedule.

A handwritten signature in black ink, appearing to be 'DM', with a long, sweeping tail that loops back to the right.

MR. DAVID MSIZA
CHIEF INSPECTOR OF MINES

SCHEDULE

Prevention of flammable gas and coal dust explosions in mines other than coal mines

Reference Number: DMRE 16/3/2/4-B5
Last Revision Date: 21 November 2019
Date First Issued: 01 February 2002
Effective Date: 01 May 2021

DEPARTMENT OF MINERAL RESOURCES AND ENERGY

MINE HEALTH AND SAFETY INSPECTORATE

**GUIDELINE FOR THE COMPILATION OF A
MANDATORY CODE OF PRACTICE FOR**

**THE PREVENTION OF FLAMMABLE GAS
EXPLOSIONS IN MINES OTHER THAN COAL
MINES**



CHIEF INSPECTOR OF MINES



**mineral resources
& energy**
Department:
Mineral Resources and Energy
REPUBLIC OF SOUTH AFRICA

Prevention of flammable gas and coal dust explosions in mines other than coal mines

CONTENTS

PART A: THE GUIDELINE	3
1. Foreword	3
2. Legal status of the guideline and COPs	3
3. The objective of this guideline	3
4. Definitions and acronyms	3
5. Scope	9
6. Members of the revision task team	9
PART B: AUTHOR'S GUIDE	11
PART C: FORMAT AND CONTENT OF THE MANDATORY COP	12
1. Title page	12
2. Table of contents	12
3. Status of the COP	12
4. Members of the drafting committee	12
5. General information	13
6. Terms and definitions	13
7. Risk management	13
8. Aspects to be addressed in the mandatory COP	14
8.1 Identification of flammable gas sources, occurrences and composition	14
8.2 Control of gas emissions	15
8.3 Detection of flammable gas	15
8.4 Reporting of flammable gas	15
8.5 Clearance of flammable gas	15
8.6 Development ends and accessible tunnels not in through ventilation	16
8.7 Mining methods	16
8.8 Stopped areas	17
8.9 Fixed installations	18
8.10 Stoppage, change or reversal in ventilation	19
8.11 Identification of hazardous locations	19
8.12 Preventing ignition of flammable gas	19
8.13 Confined space	20
PART D: IMPLEMENTATION	21
1. Implementation plan	21
2. Compliance with the COP	21
3. Access to the COP and related documents	21
ANNEXURE 1: Summary of findings of a study into flammable gas explosions in mines other than coal mines	22
ANNEXURE 2: Guidance note for lamproom practice	23
ANNEXURE 3: Guidance note for multi-blasting operations	29
ANNEXURE 4: Construction requirements for a fire seal	41
ANNEXURE 5: References	42

Prevention of flammable gas and coal dust explosions in mines other than coal mines

PART A: THE GUIDELINE

1. FOREWORD

- 1.1. **Flammable gas** may be present in the strata of all mines. The erratic occurrences of **flammable gas**, which are often of short duration, lead to a tendency to underestimate the potential dangers associated with the liberation of **flammable gasses** into the workings of a mine. This has led to an increase in the number of people fatally injured in **flammable gas** explosions in recent years.
- 1.2. Annexure 1 summarises the findings of a study into the occurrence of **flammable gas** explosions in mines other than coal mines. Annexure 1 is attached as information for consideration in the preparation of a **COP**.

2. LEGAL STATUS OF THE GUIDELINE AND COPs

- 2.1. In accordance with section 9(2) of the **MHSA** an employer must prepare and implement a **COP** on any matter affecting the health or safety of employees and other persons who may be directly affected by activities at the mines if the **CIOM** requires it. These **COPs** must comply with any relevant guideline issued by the **CIOM** (section 9(3)). Failure by the employer to prepare and implement a **COP** in compliance with this guideline is a breach of the **MHSA**.

3. THE OBJECTIVE OF THIS GUIDELINE

- 3.1. The objective of this guideline is to assist the employer of every mine, other than a coal mine, to compile a code of practice, which, if properly implemented and complied with, would considerably reduce the risk of an ignition of **flammable gas**.

4. DEFINITIONS AND ACRONYMS

- 4.1. In this guideline for a **COP** or any amendment thereof, unless the context otherwise indicates:
 - a) **“Abandoned area”** means an area in which no further mining-related activity is planned. It could be used as a return airway but is typically barricaded and/or sealed off to prevent inadvertent access. This definition also covers the term “old mined out areas” as per DMR instruction ref no. 11/4/4-9, dated 5 December 2018.
 - Mining-related activity means activities such as further blasting, cleaning, sweeping, vamping, salvage and/or material reclamation.
 - Inadvertent access means unplanned and/or unauthorised access.
 - b) **“Back stope”** means any working place where the intake and return points are situated on a common elevation whilst the panel advances towards a higher or lower elevation.
 - c) **“CIOM”** means Chief Inspector of Mines.

Prevention of flammable gas and coal dust explosions in mines other than coal mines

- d) “**Containment wall**” means a permanent wall designed for the purpose of isolating an area from the ventilation district.
- e) “**Confined space**” means an enclosed or partially enclosed space that is not intended or designed primarily as place of work. Due to its nature, a **confined space** poses particular hazards to personnel that include the potential for:
- An oxygen deficient or otherwise non-breathable atmosphere.
 - An oxygen enriched environment supportive of combustion conditions.
 - An atmosphere that is explosive or flammable.
 - An atmosphere that is toxic or contains harmful contaminants.
 - Temperature levels that pose a hazard to personnel.
 - Entrapment risks due to the nature of the **confined spaces**’ entry and exit points.
 - Engulfment risks due to the inrush of free-flowing solids or fluids.
- f) “**Contraband**” means any device for the creation of any spark or flame and / or any pipe, cigar, cigarette or tobacco other than chewing tobacco, but excluding any device used for the intentional creation of a spark for the lighting of welding or cutting torches taken underground with the written permission of the employer.
- g) “**Controlled recirculation**” means air from a working face or place which returns to the same working place or face under pre-determined conditions.
- h) “**COP**” means Code of Practice.
- i) “**Dead end**” means every unused accessible end, tunnel, shaft or heading which has advanced more than twice its width or height, whichever is the greater.
- j) “**DMRE**” means Department of Mineral Resources and Energy.
- k) “**Electrical interlocking**” means an arrangement of control electrical equipment apparatuses interconnected so that their functions occur in a predetermined sequence to assure safety; this should be listed as **electrical interlocking**.
- l) “**Explosion proof seal**” means a seal which is designed to withstand a static pressure of 140 kPa.
- m) “**Explosion protected apparatus**” means any apparatus used in a hazardous location and selected in accordance with the guidelines as defined in the South African National Standard SANS 10108-2005, (as amended). “The classification of **hazardous locations** and selection of apparatus for use in such locations

Prevention of flammable gas and coal dust explosions in mines other than coal mines

and the Aanbevole Recommended Praktyk/Practice ARP0108-2013, Regulatory requirements for **explosion protected apparatus**".

- n) **"Explosive range"** means the range between Lower Explosive Limit and Upper Explosive Limit which is determined by an appropriate methodology which is fit for purpose such as United States Bureau of Mines, Coward triangle, Le Chetalier's Rule.
- o) **"Flammable gas"** means either methane or hydrogen or other hydrocarbons or a mixture of any of gases.
- p) **"Flammable gas measuring instrument (Type A instrument)"** means **flammable gas** measuring instruments and **flammable gas** warning devices and instruments which comply with the South African Bureau of Standards Specification SANS 1515-1 as amended.
- q) **"Flammable gas trap"** means any working which is not connected at its highest point to other workings on a higher elevation than the highest point. **U-tubes** can also be regarded as gas traps.

See examples below:

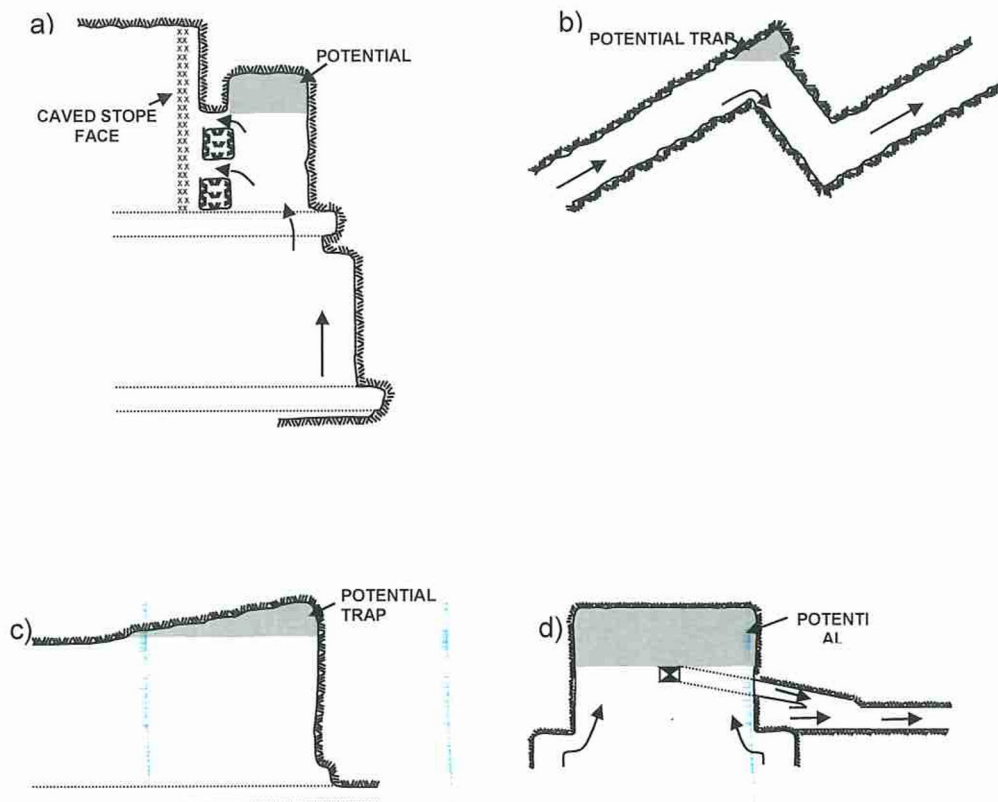

Prevention of flammable gas and coal dust explosions in mines other than coal mines

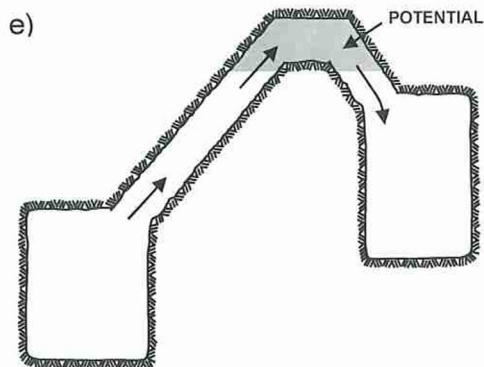

- r) “**Flammable gas warning device (Type C device)**” means a portable battery operated, continuous-duty device designed to give a clear audible and visible alarm, should it be placed in an atmosphere containing a concentration of **flammable gas**, which equals or exceeds the alarm set point.

The device may not have a facility allowing the user to turn the device off or to disable its operation in the working place and must be able to monitor and alarm; this instrument must comply with SANS 1515-2 as amended (fixed, transport and vehicle mounted **flammable gas** measuring and warning sensor heads) gas measuring equipment primarily used in mines and the SANS 10108-2013 (as amended) - regulatory requirements for explosive prevention.

- s) “**General atmosphere**” means any point outside a radius of 150 mm away from the source or point of issue of **flammable gas**.
- t) “**Hazardous location**” means any location, where there may be a significant risk of ignition gas, dust, mist, vapour, mist or vapour, including the following:
- i. For underground mines other than coal mines any location where, under normal operating conditions, there is a continuous presence of **flammable gas** measured at a concentration of 0.5% or more by volume in the air.
 - ii. For surface mines and surface location at all mines including offshore installations any location as identified in accordance with SANS 10108 as amended. The classification of **hazardous locations** and the selection of use in such locations”.

Prevention of flammable gas and coal dust explosions in mines other than coal mines

- u) **“Low Point”** means a change in the tunnel gradient that results in a **low point** being created that could close the natural air path by the accumulation of broken rock or mining water.

See example below:

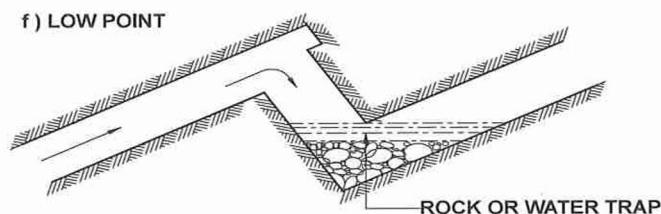

- v) **“Light-metal”** means:
- i. Aluminium;
 - ii. Magnesium;
 - iii. Titanium; and
 - iv. Any alloy containing more than:
 - 15 per cent aluminium by mass of the alloy;
 - 15 per cent aluminium, magnesium and /or titanium, taken together, by mass of the alloy; or
 - 6 per cent magnesium and /or titanium, taken together or separately, by mass of the alloy.
- w) **“MHSA”** means Mine Health and Safety Act, 1996 (Act 29 of 1996) as amended.
- x) **“Permanently stopped area”** means an area with the “footprint” of current mining operations which is intended to be stopped indefinitely, such as:
- A panel which has reached its mining limit and mining operations have ceased; or
 - A portion of a raise line which has been worked out, but where mining operations are taking place in the vicinity and the stopped area is required as a second outlet, and/or logistics supply and/or ventilation flow.
- y) **“Sealed area”** means an area which is sealed off with **explosion proof seals** or **containment walls** in accordance with this mandatory COP.
- z) **“Specialist flammable gas measuring instrument”** means an intrinsically safe instrument that indicates the presence of concentrations of **flammable gas**

Prevention of flammable gas and coal dust explosions in mines other than coal mines

in air in the range 0-100 % and is only used by a person competent in the use of this specific instrument.

- aa) **“Temporary stopped area”** means an area within the “footprint” of current mining operations which is intended to be stopped for a limited period of time, such as:
- A panel which is stopped due to leads and lags, adverse environmental conditions, etc. or
 - A winze which has reached its mining limit and is waiting for the approaching raise to hole, or
 - A re-development end which is stopped while waiting for an adjacent panel to catch up so that holing between the two can be affected.
- bb) **“Through ventilation”** means air flow, under the influence of surface fans or designated booster fan installations (installed in such a manner to assist surface main fans).
- cc) **“Uncontrolled recirculation”** of air means when any amount of air has been delivered by a particular mechanical ventilation system, re-enters the inlet of that system.
- dd) **“U-tube”** shall mean a working place where ventilation is returned from a higher or lower point back to the same elevation, and where there is no holing from the highest elevation to any other workings or airways above that elevation.

See below examples:

U-tube stoping

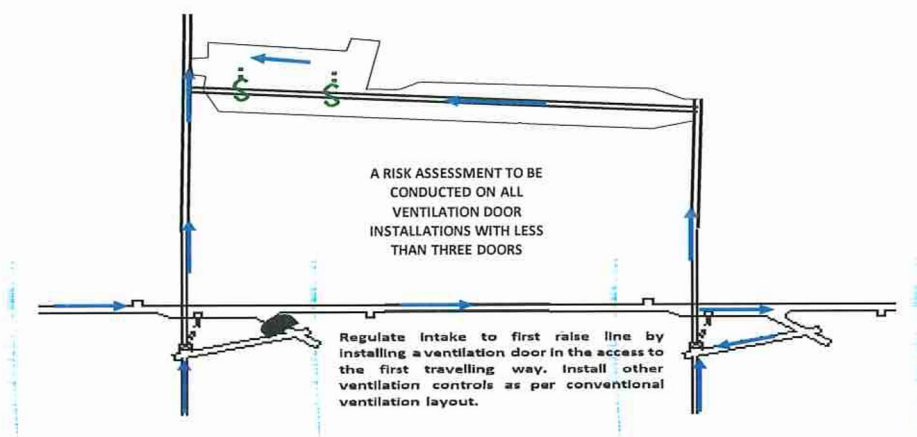

Prevention of flammable gas and coal dust explosions in mines other than coal mines

Install ventilation door set in drive between raise lines and regulate air distribution with a brattice set to ventilate the **u-tube**. Management of water control is critical.

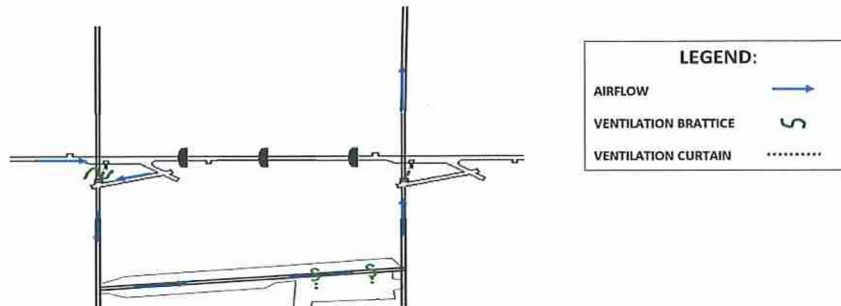

5. SCOPE

5.1. This Guideline covers issues which need to be dealt with in the **COP** in order to significantly reduce the risk of a **flammable gas** explosion in mines other than coal mines. The issues to be addressed include at least the following:

5.1.1. Identification of **flammable gas** sources, occurrences and composition:

- 5.1.1.1. Control of gas emissions.
- 5.1.1.2. Detection of **flammable gas**.
- 5.1.1.3. Reporting of **flammable gas**.
- 5.1.1.4. Dilution, removal and dispersion of **flammable gas**.
- 5.1.1.5. Development ends and accessible tunnels.
- 5.1.1.6. Stopes.
- 5.1.1.7. Stopped working spaces.
- 5.1.1.8. Clearing of **flammable gas**.
- 5.1.1.9. Ventilation controls.
- 5.1.1.10. Classification of hazardous areas; and
- 5.1.1.11. Control of Ignition Sources.

6. MEMBERS OF THE REVISION TASK TEAM

6.1. This guideline was prepared by the Occupational Hygiene Technical Task Team.

Prevention of flammable gas and coal dust explosions in mines other than coal mines

6.2. The members who were involved in the draft revision of the guideline were the following:

Messrs:	N. Mokhonoana	State
	T. Motitimi	State
	G. Mthombeni	State
Ms	C. Kekana	State
	D. Labuschagne	Employers
	M. de Koker	Employers
	B. Doyle	Employers
	R. Motlhamme	Employers
	V. De Take	Employers
	G. van der Westhuizen	Employers
	D. Mellet	Employers

6.3. The members who were involved in the final revision of the guideline were the following:

Messrs:	N. Mokhonoana	State
	T. Motitimi	State
	P. Huma	State
	G. Mthombeni	State
	B. Yates	Employers
	R. Barratt	Employers
	JC. Herbst	Employers
	J. Maass	Employers

Prevention of flammable gas and coal dust explosions in mines other than coal mines

PART B: AUTHORS GUIDE

1. The **COP** must, where possible, follow the sequence laid out in Part C: Format and content of the mandatory **COP**. All headings, paragraphs and sub-paragraphs should be numbered to facilitate cross-referencing. Wording must be unambiguous and concise.
2. It should be indicated in the **COP** and on each annex to the **COP** whether:
 - 2.1. The annexure forms part of the **COP** and must be complied with or incorporated in the **COP** or whether aspects thereof must be complied with or incorporated in the **COP**; or
 - 2.2. The annexure is merely attached as information for consideration in the preparation of the **COP** (i.e. compliance is discretionary).
3. When annexures are used the numbering should be preceded by the letter allocated to that particular annexure and the numbering should start at one again. (e.g. 1, 2 3 ...A1, A2, A3...).
4. Whenever possible illustrations, tables, graphs and the like, should be used to avoid long descriptions and/or explanations.
5. When reference has been made in the text to publications or reports, references to these sources must be included in the text as footnotes or side notes as well as in a separate bibliography.

Prevention of flammable gas and coal dust explosions in mines other than coal mines

PART C: FORMAT AND CONTENT OF THE MANDATORY COP

1. TITLE PAGE

The **COP** should have a title page reflecting at least the following:

- 1.1. Name of mine.
- 1.2. The heading: "Mandatory Code of Practice for the prevention of **flammable gas** explosions in mines other than coal mines".
- 1.3. A statement to the effect that the **COP** was drawn up in accordance with **DMRE** guideline reference number **DMR 16/3/2/4-B5** (cross referenced to DMR 16/3/2/4-A6 and DME 16/3/2/1-A2) issued by the **CIOM**.
- 1.4. The mine's reference number for the **COP**.
- 1.5. The effective date.
- 1.6. Revision dates.

2. TABLE OF CONTENTS

The **COP** must have a comprehensive table of contents.

3. STATUS OF MANDATORY COP

Under this heading the **COP** must contain statements to the effect that:

- 3.1. The mandatory **COP** was drawn up in accordance with **DMRE** guideline reference number **DMR 16/3/2/4-B5** (cross referenced to DMR 16/3/2/4-A6 and DME 16/3/2/1-A2) issued by the **CIOM**.
- 3.2. This is a mandatory **COP** in terms of sections 9(2) and (3) of the **MHSA**.
- 3.3. The **COP** may be used in an accident investigation/inquiry to ascertain compliance and to establish whether the **COP** is effective and fit for purpose.
- 3.4. The **COP** supersedes all previous relevant **COPs**.
- 3.5. All managerial instructions or recommended procedures (voluntary **COPs**) and standards on the prevention of **flammable gas** explosions must comply with the **COP** and must be reviewed to ensure compliance.

4. MEMBERS OF DRAFTING COMMITTEE

- 4.1. In terms of section 9(4) of the **MHSA** the employer must consult with the health and safety committee on the preparation, implementation or revision of any **COP**.
- 4.2. It is recommended that the employers should, after consultation with the employees in terms of the **MHSA**, appoint a committee responsible for the drafting of the **COP**.

Prevention of flammable gas and coal dust explosions in mines other than coal mines

- 4.3. The members of the drafting committee assisting the employer in drafting the **COP** should be listed giving their full names, designations, affiliations and experience. This committee should include competent persons, sufficient in number, to draft the **COP**.

5. GENERAL INFORMATION

Relevant information relating to the mine must be stated in this paragraph. The following minimum information must be provided:

- 5.1. A brief description of the mine and its location.
- 5.2. The commodities produced.
- 5.3. The mining methods/mineral excavation processes.
- 5.4. A description of the systems used at the mine to prevent **flammable gas** explosions.
- 5.5. Other relevant **COPs**.

6. TERMS AND DEFINITIONS

- 6.1. Any word, phrase or term of which the meaning is not absolutely clear, or which will have a specific meaning assigned to it in the **COP**, must be clearly defined. Existing and/or known definitions should be used as far as possible. The drafting committee should avoid jargon and abbreviations that are not in common use or that have not been defined. The definitions section should also include acronyms and technical terms used.

7. RISK MANAGEMENT

- 7.1. Section 11 of the **MHSA** requires the employer to identify hazards, assess the health and safety risks to which employees may be exposed while they are at work, record the significant hazards identified and risks assessed. The **COP** must address how the significant risks identified in the risk assessment process must be dealt with, having regard to the requirements of section 11(2) and (3) that, as far as reasonably practicable, attempts should first be made to eliminate the risk, thereafter to control the risk at source, thereafter to minimize the risk and thereafter, insofar as the risk remains, to provide personal protective equipment and to institute a programme to monitor the risk.
- 7.2. To assist the employer with the risk assessment, all possible relevant information such as accident statistics, ergonomic studies, research reports, manufacturer's specifications, approvals, design criteria and performance figures for all relevant equipment should be obtained and considered.
- 7.3. In addition to the periodic review required by section 11(4) of the **MHSA**, the **COP** should be reviewed and updated after every serious incident relating to **flammable gas**, or if significant changes are introduced to the procedures, mining and ventilation layouts, mining methods, plant or equipment and material.

Prevention of flammable gas and coal dust explosions in mines other than coal mines

8. ASPECTS TO BE ADDRESSED IN THE MANDATORY COP

The **COP** must set out how the significant risks, simplified and assessed in terms of the risk assessment process referred to in paragraph 7.1 will be addressed. Unless there is no significant risk associated with that aspect at the mine. The **COP** must cover at least the aspect set out below:

8.1. Identification of flammable gas sources, occurrences and composition

In order to ensure that the identification of **flammable gas** sources, occurrences and compositions are addressed, the **COP** must cover at least the following:

- 8.1.1. A description of the sources of **flammable gas**, the way that **flammable gas** is encountered or likely to be encountered and how it enters the workings of the mine, for example:
 - 8.1.1.1. Ingress through faults, dykes, fissures or other geological features.
 - 8.1.1.2. High pressure pockets.
 - 8.1.1.3. From worked out and/or **abandoned areas**, through seals.
 - 8.1.1.4. Cover drilling.
 - 8.1.1.5. Pilot hole drilling.
 - 8.1.1.6. Normal shot hole drilling.
 - 8.1.1.7. Blast and seismic induced fracture planes.
 - 8.1.1.8. Occurrence of **flammable gas** with water.
 - 8.1.1.9. Change in barometric pressure.
 - 8.1.1.10. Change in season.
 - 8.1.1.11. Long term emitters.
- 8.1.2. A procedure for identifying and recording **flammable gas** intersections.
- 8.1.3. A procedure to deal with **flammable gas** intersections, and allocation of responsibilities to competent persons.
- 8.1.4. A procedure for sampling the gas at every **flammable gas** intersection where the **flammable gas** concentration in the **general atmosphere** exceeds 1.4% by volume, to determine the composition and concentration in order to identify the upper and lower explosive limits of the gas source.

Prevention of flammable gas and coal dust explosions in mines other than coal mines

8.2. Control of gas emissions

- 8.2.1. The **COP** must set out precautionary measures to be taken to control the release of **flammable gas**, inclusive of when sealing of an area or bleeding of gas from an area should be done.

8.3. Detection of flammable gas

(See Annexure 2 – Guidance Note for Lamproom Practice, for information purposes)

The **COP** must set out a procedure to detect **flammable gas**, which must deal with the following aspects:

- 8.3.1. Selection of appropriate **flammable gas** detection instruments for the typical operational conditions.
- 8.3.2. Availability for allocations, at any time, of a sufficient number of the **flammable gas** detection instruments referred to in (8.3.1 above).
- 8.3.3. Issuing of **flammable gas** detection instruments to employees on the mine.
- 8.3.4. Testing for and dealing with the presence of **flammable gas**.
- 8.3.5. Maintenance and calibration of **flammable gas** instruments.
- 8.3.6. Training and presence of competent persons for performing **flammable gas** detection measurements, inclusive of the correct selection, use and care of **flammable gas** detection instruments.

8.4. Reporting of flammable gas

In order to ensure that **flammable gas** intersections are reported, the **COP** must cover at least the following:

- 8.4.1. A procedure for the reporting of **flammable gas** as required per Mine Health and Safety Act Regulation 23.4 (g).
- 8.4.2. A procedure for the reporting, internal and/or external, of all other **flammable gas** incidents in the **general atmosphere** not covered by paragraph 8.4.1.

8.5. Clearance of flammable gas

In order to ensure that the clearance of **flammable gas** accumulations, including roof layers, is done safely, the **COP** must set out a procedure for:

- 8.5.1. The dilution, removal and dispersion of **flammable gas**, including roof layering.
- 8.5.2. Isolating electricity without affecting the ventilation system where applicable.
- 8.5.3. Withdrawing of people from the return.

Prevention of flammable gas and coal dust explosions in mines other than coal mines

8.6. Development ends and accessible tunnels not in through ventilation

(See Annexure 3 - Guidance Note for Multi-blasting Operations, for information purposes)

In order to ensure that the build up of **flammable gas** in development ends and accessible tunnels not in **through ventilation** is prevented the **COP** must cover at least the following:

- 8.6.1. Minimum air quantity.
- 8.6.2. Minimum air velocity.
- 8.6.3. Ventilation column sizes for the different applications.
- 8.6.4. Fan types, sizes and positions.
- 8.6.5. Ventilation methods.
- 8.6.6. Restrictions on ventilation column size and distance.
- 8.6.7. Maximum distance of a ventilation column discharge from the face in tunnels, raises, winzes and boxholes.
- 8.6.8. Minimum and maximum overlap distances of ventilation systems.
- 8.6.9. Methods of ensuring that the force volume is always directed to the working face.
- 8.6.10. Blasting frequency.
- 8.6.11. Blasting method and re-entry period.
- 8.6.12. How development ends in series should be ventilated and restrictions on the maximum number of ends that may be ventilated in series.
- 8.6.13. Methods to ensure **uncontrolled recirculation** does not take place.
- 8.6.14. Methods of breaking away a new end from an existing end or tunnel.
- 8.6.15. The installation of electrical equipment beyond the last point of **through ventilation** and applicable safety precautions.

8.7. Mining methods

8.7.1. Conventional mining (stopes)

In order to ensure that the build up of **flammable gas** in stopes is prevented, the **COP** must cover at least the following:

- 8.7.1.1. The minimum air quantity per stope.
- 8.7.1.2. Minimum air velocity in a stope.

Prevention of flammable gas and coal dust explosions in mines other than coal mines

8.7.1.3. The installation of electrical equipment and safety precautions applicable thereto.

8.7.1.4. Special detailed precautions for **back stopes** and inverted **U-tubes**.

8.7.2. Mechanised mining

8.7.2.1. The minimum air quantity per stope.

8.7.2.2. Minimum air velocity in a stope.

8.7.2.3. The installation of electrical equipment and safety precautions applicable thereto.

8.8. Stopped areas

8.8.1. Temporarily stopped working place

In order to ensure that the build-up of **flammable gas** in temporarily stopped areas is prevented, the **COP** must set out procedures to cover at least the following:

8.8.1.1. Circumstances under which areas can be temporarily stopped.

8.8.1.2. Methods of preventing access to temporarily stopped areas, such as barricading.

8.8.1.3. For removing the ventilation system.

8.8.1.4. To monitor any build-up of **flammable gas**.

8.8.2. Permanently stopped working place

In order to ensure that the build up of **flammable gas** is prevented, or **flammable gas** is safely accumulated in **permanently stopped areas**, the **COP** must set out procedures to cover at least the following:

8.8.2.1. Prevention of **flammable gas** build-up:

(i) Circumstances under which areas can be permanently stopped.

(ii) Method of removing the ventilation system.

(iii) Monitoring of any build-up of **flammable gas**.

8.8.2.2. Safe accumulation of **flammable gas**:

(i) Measures to ensure that **containment walls** are provided with means to monitor any build-up of **flammable gas** behind such walls.

(ii) Measures to ensure that explosive proof seals are used and demarcated where the atmosphere of **sealed areas** stabilises within the **explosive range**.

Prevention of flammable gas and coal dust explosions in mines other than coal mines

(iii) Measures for the monitoring of the atmosphere within the **sealed area**.

8.8.3. Approaching and holing into stopped areas

In order to ensure that the approaching or holing into temporarily or permanent stopped areas is done safely, the **COP** must cover at least the following:

- 8.8.3.1. Procedures to ensure warning notes are timeously issued by the surveyor when any workings approach any stopped area.
- 8.8.3.2. Stopping distances of workings approaching stopped areas.
- 8.8.3.3. Maximum excavation sizes of workings approaching any stopped area.
- 8.8.3.4. Procedure to probe for water and gas accumulations in any stopped area.
- 8.8.3.5. Procedure of re-establishing ventilation in any stopped area before and after holing.

8.9. Fixed installations

- 8.9.1. In order to ensure that **flammable gas** accumulations at fixed installations are prevented, the **COP** must set out procedures to cover at least the following:
- 8.9.2. A layout that indicates the positions of the ventilation appliances in the areas mentioned hereunder must be drawn up.
- 8.9.3. Main surface and underground booster fans.
- 8.9.4. Fixed installations

For the purpose of this guideline fixed installations refers to e.g.:

- 8.9.4.1. Pump stations;
- 8.9.4.2. Dams, sumps, silos and settlers;
- 8.9.4.3. Shaft bottoms;
- 8.9.4.4. Belts;
- 8.9.4.5. Workshops;
- 8.9.4.6. Battery bays;
- 8.9.4.7. Repair bays;
- 8.9.4.8. Cutting and welding bays;
- 8.9.4.9. Sub-stations;

Prevention of flammable gas and coal dust explosions in mines other than coal mines

- 8.9.4.10. Mini sub-stations;
- 8.9.4.11. Refrigeration chambers;
- 8.9.4.12. Stores; and
- 8.9.4.13. Hoist rooms.

8.10. **Stoppage, change or reversal in ventilation**

In order to ensure that employees are not exposed to risks associated with **flammable gas**, the **COP** must set out procedures to be followed for the immediate withdrawal from, and subsequent return of employees to, the working area in the event of a stoppage, noticeable change or reversal in the ventilation in that working area.

8.11. **Identification of hazardous locations**

The **COP** should describe a process for identification of **hazardous locations** and the measures to be taken to prevent **flammable gas** explosions in those locations.

8.12. **Preventing ignition of flammable gas**

In order to ensure the controlling of potential ignition sources the **COP** must cover at least the following:

8.12.1. Contraband

- 8.12.1.1. Orientation of employees regarding the risks of taking **contraband** into underground mines.
- 8.12.1.2. Methods of warning employees of the dangers of taking **contraband** into demarcated areas.
- 8.12.1.3. The random searching of employees about to proceed into or while in demarcated areas.
- 8.12.1.4. Use of light Metals SANS 10012 as amended.

8.12.2. Open flame and other ignition sources

- 8.12.2.1. Safe procedures for welding, flame cutting, flame heating, and similar work such as friction cutting, grinding, vulcanizing, soldering, photography, video, and any other electronic devices.
- 8.12.2.2. The training of competent persons to perform such work.
- 8.12.2.3. Issuing and control of flint lighters and short exploders.
- 8.12.2.4. The construction, ventilation, physical characteristics and orderly maintenance of the workshop and cutting bays so that work can be performed in a safe and healthy manner.

Prevention of flammable gas and coal dust explosions in mines other than coal mines

- 8.12.2.5. Precautions to be taken when working outside approved workshops or cutting bays.
- 8.12.2.6. The ventilation, inertisation, fire prevention and the gas testing procedure before, during and on completion of such work.
- 8.12.2.7. The precautions and devices utilized to quench flashback and to prevent back feeding of gas.
- 8.12.2.8. The proper transport, storage and use of gas cylinders.
- 8.12.2.9. The issuing, safekeeping and examination of both equipment and devices used.
- 8.12.3. Electrical equipment
 - 8.12.3.1. Where **explosion protected apparatus** are used.
 - 8.12.3.2. Where the use of electrical equipment requires special precautions.
 - 8.12.3.3. For interlocking of fans ventilating in series and other electrical equipment used within relevant areas.
 - 8.12.3.4. For the positioning of fans in series.
 - 8.12.3.5. For the positioning of switchgear in development ends.
 - 8.12.3.6. For **flammable gas** tests before starting or stopping electrical equipment.
 - 8.12.3.7. For identification of electrical equipment that poses a significant risk and measures to deal with that risk.
 - 8.12.3.8. No automatic re-starting of auxiliary (development end) fans and other electrical equipment.

8.12.4. Frictional ignitions

Identify potential sources of frictional ignition and detail the relevant prevention and control measures.

8.12.5. Static electricity

Identify the potential sources of static electricity and detail relevant prevention and control measures.

8.13. **Confined space**

In order to ensure the prevention of an explosion in a **confined space** the **COP** must cover at least the following:

- 8.13.1. The measures to prevent the accumulation and ignition of **flammable gas** and/or explosive mixtures in confined areas.

Prevention of flammable gas and coal dust explosions in mines other than coal mines

PART D: IMPLEMENTATION

1. Implementation plan

- 1.1. The employer must prepare an implementation plan for the **COP** that makes provision for issues such as organisational structures, responsibilities of functionaries and programmes and schedules for this **COP** that will enable proper implementation of the **COP**. (A summary of/and a reference to, a comprehensive implementation plan may be included).
- 1.2. Information may be graphically represented to facilitate easy interpretation of the data and to highlight trends for the purpose of risk assessment.

2. Compliance with the COP

- 2.1. The employer must institute measures for monitoring and ensuring compliance with the **COP**.

3. Access to the COP and related documents

- 3.1. The employer must ensure that a complete **COP** with related documents is kept readily available at the mine for examination by any affected person.
- 3.2. A registered trade union with members at the mine or where there is no such union, a health and safety representative on the mine, or if there is no health and safety representative, an employee representing the employees on the mine, must be provided with a copy on written request to the employer. A register must be kept of such persons or institutions with copies to facilitate updating of such copies.
- 3.3. The employer must ensure that all employees are fully conversant with those sections of the **COP** relevant to their respective areas of responsibility.

Prevention of flammable gas and coal dust explosions in mines other than coal mines

ANNEXURE 1: Summary of findings of a study into flammable gas explosions in mines other than coal mines
(For information purposes only)

1. BACKGROUND

A study into the occurrence of **flammable gas** on mines other than coal mines has revealed the following six points to prevent a **flammable gas** explosion.

1.1. Always expect gas.

1.2. Be aware.

There is a general lack of awareness of the presence and hazards associated with **flammable gas**. Only four mines in the country considered **flammable gas** to be a significant problem. This is reflected in the fact that although the fatality trend in the industry is down the trend on **flammable gas** fatalities is up.

1.3. Know what gas you are dealing with.

1.4. Determine the combustible properties of the gas mixture.

1.5. Are your **flammable gas** detectors reading correctly?

1.6. Know your probable gas sources.

- Methane and hydrogen are not the only **flammable gases** present in mines. The employer must know the gases it is dealing with in order to institute proper calibration and testing procedures.
- Gas samples must be analysed because it is the only way to determine the composition of gases the mine is dealing with.
- All employees must know the circumstances in which gas is likely to occur.
- This Guideline and the Code of Practice to which it refers will deal with identifying possible gas emissions, controlling the emissions where possible, early detection of **flammable gas** and good ventilation practice. Combined, these interventions should ensure that **flammable gas** explosions should not occur.

Prevention of flammable gas and coal dust explosions in mines other than coal mines

ANNEXURE 2: Guidance note for lamproom practice
(For information purposes only)



DEPARTMENT: MINERALS AND ENERGY
Minerals and Energy for Development and Prosperity
Mine Health and Safety Inspectorate

**GUIDANCE NOTE
FOR
LAMPROOM PRACTICE**

CHIEF INSPECTOR OF MINES

Date First issued:
Effective date:

Prevention of flammable gas and coal dust explosions in mines other than coal mines

CONTENTS	PAGE NO
1. INTRODUCTION	25
2. LEGAL STATUS	25
3. DEFINITIONS	25
3.1 Equipment	25
3.2 Gas detection instrumentation	25
3.2.1 Flammable gas measuring instruments and flammable gas warning devices	25
3.2.2 Carbon monoxide warning devices	25
3.3 Self-contained self-rescuers	25
3.4 OEM	25
4. COMPETENT PERSON	25
4.1 Appointment	25
4.2 Training	25
5. CERTIFICATION OF SPECIFICATION COMPLIANT	26
5.1 Gas detection instruments	26
5.1.1 Flammable gas	26
5.1.2 Carbon monoxide	26
5.2 Self-contained self-rescuers	26
5.3 Portable lamps	26
6. ALLOCATION OF EQUIPMENT	26
6.1 Gas detection instrumentation	26
6.1.1 Flammable gas	26
6.1.2 Carbon monoxide	26
6.2 Self-contained self-rescuers	27
7. STORAGE EQUIPMENT	27
8. EQUIPMENT CONTROL	27
8.1 Checking/testing	27
8.2 Calibration (gas detection instrumentation)	27
8.3 General maintenance	27
8.3.1 Gas detection instrumentation and portable lamps	27
8.3.2 Self-contained self-rescuers	27
8.4 Battery charging programme (gas detection instrumentation and portable lamps)	28
8.5 Records	28
9. REPORTING	28
10. COMPLIANCE TESTS	28

Prevention of flammable gas and coal dust explosions in mines other than coal mines

1. INTRODUCTION

These guidance notes have been primarily prepared to assist the employer in ensuring that gas detection instrumentation, self-contained self-rescuers and portable lamps are in proper working order prior to going on shift.

2. LEGAL STATUS

- 2.1 This guidance note has been compiled to assist employers in preparing a Code of Practice for Lamproom Practice.
- 2.4 A guidance note sets out good practice and will be widely distributed by the Mine Health and Safety Inspectorate within the industry. As is the case with all other documents setting out accepted good practice, the application of inferior practices without justification could amount to negligence.

3. DEFINITIONS

- 3.1 **“Equipment”** means gas detection instrumentation, self-contained self-rescuers and portable lamps.

3.2 Gas detection instrumentation

- 3.2.1 **“Flammable gas measuring instruments and flammable gas warning devices”** means only those instruments and devices which comply with the South African Bureau of Standards specification SANS 404545.1515.
- 3.2.2 **“Carbon monoxide warning devices”** means only those devices which are battery operated portable personal units, capable of continuously sensing and able to give either a clearly audible or a clearly visible warning or both a clearly audible and a clearly visible warning should they be used in an atmosphere containing 100 ppm or more of carbon monoxide.
- 3.3 **“Self-Contained Self-Rescuers”** means a body-worn device, which complies with the South African Bureau of Standards specification SANS 1737.

- 3.4 **“OEM”** means original equipment manufacturer.

4. COMPETENT PERSON

4.1 Appointment

The Manager shall appoint a competent person who shall have successfully completed a training programme drawn up by the manager, and clearly define all his duties and responsibilities in writing.

4.2 Training

- (i) The Manager, in consultation with the **OEM** of the equipment in use on the mine, shall draw up a mine specific training programme.

Prevention of flammable gas and coal dust explosions in mines other than coal mines

- (ii) Refresher courses to be conducted annually and retraining done in the event of any change in specification of any equipment.

5. CERTIFICATION OF SPECIFICATION COMPLIANT

5.1 Gas detection instrumentation

The following is recommended for all specification compliant equipment in the lamproom:

5.1.1 Flammable gas

Copies of the SANS 1515-1 test certificates and the list showing the relevant serial numbers of all specification compliant instruments and devices in use should be displayed in the lamproom.

5.1.2 Carbon monoxide

Copies of the SANS 1515-3 test report for explosion protection for all battery powered portable personal warning devices in use shall be displayed in the lamproom.

5.2 Self-contained self-rescuers (SCSRs)

Copies of SANS 1737 batch test certificates for units purchased after 1 September 2002 of all makes of SCSR in use on the mine should be displayed in the lamproom.

5.3 Portable lamps

Copies of all schedules giving full details and specifications of all portable lamps in use, on the mine shall be displayed in the lamproom.

6. ALLOCATION OF EQUIPMENT IN COMPLIANCE WITH SABS SPECIFICATIONS

6.1 Gas detection instrumentation

6.1.1 Flammable gas

Every designated person who is required to conduct tests or monitor for **flammable gas** is to be allocated a personal **flammable gas** measuring instrument or a personal **flammable gas warning device** as the case may be.

6.1.2 Carbon monoxide

Every designated person who is required to monitor carbon monoxide is to be allocated a personal carbon monoxide warning device.

6.1.3 Sensor for oxygen deficiency (please suggest a description for other gases)

Prevention of flammable gas and coal dust explosions in mines other than coal mines

6.2 Self-contained self-rescuers

Every person who is required to be equipped with a self-contained self-rescuer under Regulation 16 of the MHSA Act No. 29 of 1996 shall be allocated such for their sole use.

7. STORAGE OF EQUIPMENT

- (i) Equipment should be stored in accordance with **OEM** recommendations.
- (ii) Storage area to be clean, oil free, free of silicone-based cleaners, well ventilated and well illuminated.
- (iii) Due to the nature of the reactive chemicals contained in SCSRs, any unit which has been activated, vandalised, damaged, or which has failed the routine inspection including redundant units, should be immediately withdrawn from service and sealed in an impervious plastic bag and kept in an area away from other equipment. For safe disposal of these particular units it is recommended that they be returned to the **OEM** concerned.

8. EQUIPMENT CONTROL

8.1 Checking/testing

- (i) The appointed competent persons shall test and check equipment in accordance with a procedure drawn up by the manager in consultation with the **OEM** to verify that the equipment is in proper working order prior to each shift.
- (ii) With regard to SCSRs a special monitoring test programme by an approved testing authority should be implemented in accordance with Regulation 16.4 (1) of the Mine Health and Safety Act (Act 26 of 1996).

8.2 Calibration of Portable Gas Detection Instruments

Calibration of portable instruments should be done in accordance with a procedure drawn up by the employer in consultation with the **OEM**.

8.3 General maintenance

8.3.1 Gas detection instrumentation and portable lamps

- (i) Separate rooms for gas detection instrumentation and portable lamps should be dedicated for maintenance purposes.
- (ii) Portable lamp repairs may be effected by the appointed competent person but in the case of gas detection instrumentation only the **OEM** or their accredited authorities may carry out any repair.

8.3.2 Self-contained self-rescuers

Repairs and/or refurbishment shall be effected only by the **OEM** or by their accredited authorities.

Prevention of flammable gas and coal dust explosions in mines other than coal mines

8.4 Battery charging programme (gas detection instrumentation and portable lamps)

Batteries are to be charged in accordance with a procedure drawn up by the manager in consultation with the **OEM**.

8.5 Records

- (i) A record shall be kept for a period of 12 months in the lamproom of specific persons to whom equipment are issued in order that the user can at any time be identified from the records.
- (ii) With regard to SCSRs a comprehensive record system should be implemented in accordance with Regulation 16.4(2) of the Mine Health and Safety Act (Act 26 of 1996).
- (iii) In the case of gas detection instrumentation records of individual instruments and devices showing a history of testing, calibration and maintenance, shall be kept.

9. REPORTING

- (i) The lampsman shall on a monthly basis report in writing to the Manager on all matters pertaining to the control of equipment.
- (ii) Copies of these reports shall be kept for a period of one year.

10. COMPLIANCE TESTS

Tests and checks of equipment shall be made by the designated user in accordance with a procedure drawn up by the manager. A means of acknowledgement by the designated user shall be instituted to verify that such tests and checks have been conducted prior to going on shift and recorded.

Prevention of flammable gas and coal dust explosions in mines other than coal mines

ANNEXURE 3: Guidance note for multi-blasting operations
(For information purposes only)

REF: 24/2/P
LAST REVISION DATE:



DEPARTMENT: MINERALS AND ENERGY
Minerals and Energy for Development and Prosperity
Mine Health and Safety Inspectorate

**GUIDANCE NOTE
FOR
MULTIBLASTING OPERATIONS**

**RE-ENTRY INTERVAL AFTER BLASTING AND PERMISSION TO BLAST MORE THAN
ONCE IN 24 HOURS IN TERMS OF REGULATION 9.2(1)**

CHIEF INSPECTOR OF MINES

Date First issued:
Effective date:

Prevention of flammable gas and coal dust explosions in mines other than coal mines

CONTENTS

ACRONYMS	31
1 INTRODUCTION	31
2 LEGAL STATUS	31
3 RELEVANT PROVISIONS OF THE MHSA	31
4 DEFINITIONS	32
5 RE-ENTRY INTERVALS	32
5.1 Nil re-entry interval	32
5.2 General re-entry interval	32
5.3 Multi-blast re-entry interval	33
5.4 Fixed-time multi-blast re-entry interval	35
6 RISK ASSESSMENT	36
6.1 Aspects to be addressed	36
6.2 Waiting place	36
6.3 Miscellaneous	36
7 CALCULATION OF THE RE-ENTRY INTERVAL FOR A DEVELOPMENT END	37
8 CALCULATION OF THE RE-ENTRY INTERVAL FOR SEQUENTIALLY VENTILATED DEVELOPMENT ENDS	37
9 ADVANTAGES AND DISADVANTAGES OF FORCED AND EXHAUST OVERLAP SYSTEMS	39
REFERENCES	40

Prevention of flammable gas and coal dust explosions in mines other than coal mines

ACRONYMS

MHSA	Mine Health and Safety Act, Act 29/1996
RAW	Return airway
l	Length
w	Width
h	Height
m/s	Metres per second
m ³ /s	Cubic metres per second
m ³ /s/m ²	Cubic metres per second per square meter
Q _F	Force quantity

1. INTRODUCTION

This guidance note is not applicable to collieries.

A recent mine disaster has brought the blasting and ventilation arrangements, especially regarding development multi-blasting, into urgent need of review. It furthermore highlighted that the increased risk of **flammable gas** explosions, in underground metalliferous mines, must be managed.

This guidance note has been amended in line with the Industry Best Practice Guideline produced by the Group Environmental Engineers, submitted through the Chamber of Mines. The purpose of this guidance note is to ensure that the re-entry periods applied under differing occupational environmental conditions ensure that no persons are exposed to occupational health risks.

2. LEGAL STATUS

This guidance note has been compiled to assist mines with the calculation of re-entry periods for the different types of multi-blasting.

A guidance note sets out good practice and will be widely distributed by the Mine Health and Safety Inspectorate within the industry. As in the case with all other documents setting out accepted good practice, the application of inferior practices without justification could be regarded as negligence.

3. RELEVANT PROVISIONS OF THE MHSA

- 3.1 The employer must assess the hazards and respond to the risks to health and safety, in terms of Section 11 of the **MHSA**, to which employees may be exposed while they are at work.
- 3.2 The employer must establish and maintain a system of occupational hygiene measurements and engage the part-time or full-time services of a person qualified in occupational hygiene techniques to measure levels of exposure to hazards at the mine, in terms of Section 12.(1) of the **MHSA**.
- 3.3 Every system of occupational hygiene measurements must be appropriate in terms of the hazards to which employees are, or may be, exposed and must provide information, which the employer can use to eliminate, control and minimise such health risks and hazards, in terms of Section 12.(2) of the **MHSA**.

Prevention of flammable gas and coal dust explosions in mines other than coal mines

- 3.4 Records must be kept of all such measurements in order that it can be linked, as far as practicable, to an employee's records of medical surveillance, in terms of Section 12.(3) of the MHSA.

4. DEFINITIONS

In order to differentiate between mining operations using multi-blasting and time blasting, these definitions will apply. It should be noted that in all three definitions cognisance must be taken of the occupational hygiene regulations, which requires that no persons must be exposed to airborne contaminants.

Time-blasting

Blasting operations taking place not more than once in any 24-hour cycle (as per paragraph 5.2).

Multi-blasting

Multiple blasting including shaft sinking operations, which could take place during any working shift. Such blasting may only take place where efficacious means of separating intake and return air e.g. a dedicated return airway is provided (as per paragraph 5.3).

Fixed-time multi-blasting

Blasting more than once per 24 hours, but not more than once per shift, for both stoping and development, taking cognisance of a re-entry period sufficient to clear all airways where persons are expected to work or travel (as per paragraph 5.4).

The re-entry period must be determined by a risk assessment and validated whenever key factors, that can have a significant effect on the re-entry conditions, change.

5. RE-ENTRY INTERVALS

In terms of Regulation 9.2(1) of the **MHSA** the employer must ensure that the occupational exposure to health hazards of employees is maintained below the limits set out in Schedule 22.9(a) and (b). The intervals which must expire before persons are allowed to re-enter the workings of your mine in which blasting has taken place, should be fixed as follows:

5.1 Nil re-entry interval

A re-entry interval need not be observed where persons are expected to work or travel if uncontaminated **through ventilation** has been established and is effective / operational.

5.2 General re-entry interval

Should blasting fumes however contaminate the air in any of the workings the general re-entry interval, as set out in the paragraph below, must be observed in those workings.

Prevention of flammable gas and coal dust explosions in mines other than coal mines

A general re-entry interval after the blast in all ventilation districts must be observed in terms of Regulation 9.2.1: "The employer must ensure that the occupational exposure to health hazards of employees is maintained below the limits set out in Schedule 22.9(2)(a) and (b)". This re-entry interval must be determined after a detailed and recorded risk assessment and excludes the workings mentioned in paragraphs 5.1, 5.3 and 5.4.

5.3 Multi-blast re-entry interval

In terms of Regulation 9.2.1 the employer must ensure that the occupational exposure to health hazards of employees is maintained below the limits set out in Schedule 22.9(2)(a) and (b).

A minimum 30-minute re-entry interval must be observed, and the following provisions must be made applicable to all multi-blast development ends or shafts being sunk:

5.3.1 *Minimum air quantities required (relative to the air density at the working face)*

5.3.1.1 The quantity of air forced shall be established through a risk assessment process to ensure that the air supplied is of a quality as set out in Schedule 22.9 (2) (a) and (b) and should not be less than 0,25 m³/s for every square meter of face area, for all multi-blast development ends.

5.3.1.2 The quantity of air exhausted from the development end should be not less than twice more than the quantity of air supplied by the force column referred to in paragraph 5.3.1.1 above. A minimum force exhaust ratio of 1:2 should be maintained at all times to ensure that no uncontrolled re-circulation takes place in the overlap section.

5.3.2 *Ventilation arrangements*

5.3.2.1 Horizontal development, inclines, declines and raises.

5.3.2.1.1 An exhaust-overlap system of ventilation should be used for every end being multi-blasted.

5.3.2.1.2 The intake of the exhaust column should be carried to a point not exceeding thirty (30) metres from the face.

5.3.2.1.3 The distance between the discharge of the force column and the advancing face must be such as to ensure that the ventilating air reaches the face and should not be more than twenty (20) metres from the face of the end after the blast.

5.3.2.1.4 The minimum overlap distance between the exhaust column intake and the force column intake points should be at least 10 metres and not exceeding 25 metres.

Prevention of flammable gas and coal dust explosions in mines other than coal mines

- 5.3.2.1.5 Fans in the exhaust column should be positioned in such a manner that the exhaust column remains under negative pressure, thus ensuring that no exhaust fumes leak back into the intake air flowing to the face.
- (a) To prevent open circuit exhaust fans from recirculating, sufficient **through ventilation**, at least $0.4 \text{ m}^3/\text{s}/\text{m}^2$ of **through ventilation**, should be provided at these fan sites at all times.
 - (b) The exhaust fans in an exhaust-overlap system, which are the primary source of ventilation, should be interlocked with all other electrical appliances and equipment in the end being multi-blasted. This is to ensure that, in the event of the exhaust fans stopping, all other electrical appliances and equipment will also shut down.
 - (c) No butterfly valves must be positioned in any exhaust column in development ends.
- 5.3.2.1.6 The force fan must be positioned only in the overlap section of the ventilation system.
- 5.3.2.1.7 An effective dust allaying mechanism must be operated during the blast and re-entry period at a discharge point not exceeding 20 metres from the face.
- 5.3.2.1.8 If, at any stage, blasting fumes from the end being multi-blasted contaminates any working places in the vicinity, then multi-blasting must cease and conventional time blasting (as per paragraph 5.2) or fixed-time blasting (as per paragraph 5.4) must be followed until conditions have been rectified for multi-blasting. The ends so contaminated must also of necessity be on conventional time blasting.
- 5.3.2.1.9 The dust and fumes from blasting operations must be exhausted directly to surface via an established RAW and must not contaminate any place where persons may be required to work or travel.
- 5.3.2.1.10 The number of air changes, calculated on the volume of air between the face and the intake of the force column, required shall be determined through a risk assessment process to ensure that on re-entry after the blast the air in the development end is of a quality as set out in Schedule 22.9 (2) (a) and (b) and should not be less than 8.

NB: For raises, winzes and declines the following will, in addition, apply:

- (a) The exhaust column intake must be situated in the crosscut; and
- (b) Ore passes must never be completely empty, to prevent re-circulation.

Prevention of flammable gas and coal dust explosions in mines other than coal mines

5.3.3 Shafts

5.3.4 The bank area must be kept clear of blasting fumes and the shaft must remain downcasting, in the bank area, at all times.

5.3.4.1 The force column delivery must at least be to the bottom deck of the stage during blasting.

5.3.5 *Compliance testing*

5.3.5.1 Workplace environmental conditions on re-entry must be of a quality as set out in Schedule 22.9(2)(a) and (b).

5.3.5.2 Gravimetric dust measurement results on re-entry with a tyndallometer or similar dust-measuring instrument must be less than an AQI of 1,0 taken over a 2-minute period, using previously determined hazardous pollutant values.

5.3.6 *Blasting initiation*

Blasting initiation must be conducted electrically.

5.4 Fixed-time multi-blast re-entry interval

For blasting more than once in 24 hours, but not more than once per shift, a minimum re-entry interval will be determined after a detailed and recorded risk assessment with the following provisions made applicable to all fixed-time multi-blast development ends or stopes:

5.4.1 *Minimum air quantities required (relative to the air density at the working face)*

5.4.1.1 The quantity of air forced shall be established through a risk assessment process to ensure that the air supplied is of a quality as set out in Schedule 22.9 (2) (a) and (b) and should not be less than 0, 15 m³/s for every square metre of face area, for all multi-blast development ends.

5.4.1.2 The minimum stope face velocity averaged across the height of the stope should be determined through a risk assessment process to ensure that the quality of air is such that it meets the requirements as laid down in Schedule 22.9 (2) (a) and (b) and should not be less than 0.25 m/s. This should vary when determining the desired re-entry interval.

5.4.1.3 The number of air changes, calculated on the volume of air between the face and the intake of the force column, required shall be determined through a risk assessment process to ensure that on re-entry after the blast the air in the development end is of a quality as set out in Schedule 22.9 (2) (a) and (b) and should not be less than 8. The risk assessment must take into account all areas that maybe contaminated by the blast including "kickback".

Prevention of flammable gas and coal dust explosions in mines other than coal mines

5.4.2 *Compliance testing*

5.4.2.1 Workplace environmental conditions on re-entry must be of a quality as set out in Schedule 22.9(2)(a) and (b).

5.4.2.2 Dust measurement results on re-entry, with a tyndallometer or similar dust-measuring instrument, must be less than an AQI of 1,0 taken over a 2-minute period, using previously determined hazardous pollutant values.

5.4.3 *Blasting initiation*

Blasting initiation must be conducted electrically.

6. RISK ASSESSMENT

6.1 Aspects to be addressed

The risk assessment must, at least, cover the following;

6.1.1 A risk-assessment must be conducted and recorded on the specific operation.

6.1.2 Appropriate exposure measurements and environmental engineering controls must be put in place to comply with legal occupational hygiene requirements.

6.1.3 Hazards to be taken into account when conducting a risk assessment should include, but not limited to, the following:

- Noxious fumes from blasting;
- Dust created by blasting;
- **Flammable gas**;
- Thermal environment; and
- Diesel emission

6.2 Waiting Place

6.2.1 Blasting must be carried out from a place of safety demarcated by the manager. This position must be sign posted as "Waiting Place" and also act as a **contraband** control point, where applicable.

6.2.2 The blasting times must be recorded, and the re-entry interval must be specified and posted on the waiting place signboard and other relevant conspicuous places.

6.3 Miscellaneous

6.3.1 Continuously operating **flammable gas** measuring instruments must be used at all drilling sites (inclusive of cover/diamond/prospect drilling sites).

6.3.2 All calculations must be done and verified by the person engaged in terms of section 12.1 of the MHSA.

6.3.3 Your attention is also drawn to the MHSA Regulations published in the Government Gazette No. 23583, dated 2 July 2002. The following regulations must be noted: 9.1(3), 9.1(4) and 9.2(1).

Prevention of flammable gas and coal dust explosions in mines other than coal mines

6.3.4 All persons concerned must be made fully conversant with the terms of this guidance note, copies of which must be readily available to them.

7. CALCULATION OF THE RE-ENTRY INTERVAL FOR A DEVELOPMENT END

$$\frac{\text{Volume of end } (l \times w \times h) \times \text{air changes}}{\text{Force air volume } (Q_F) \times 60(\text{min})}$$

$$\therefore \text{Re-entry period (minutes): } \frac{\text{Volumetric capacity} \times 8}{Q_F \times 60}$$

\therefore For an end 100m long, 4m high x 4m wide, with a force quantity of 10m³/s and 8 air changes:

$$= \frac{100 \times 4 \times 4 \times 8}{10 \times 60} \text{ minutes}$$

$$= 21 \text{ minutes}$$

For multiple ends, ventilated **sequentially**, the re-entry period will be the sum of the individual end re-entries, **plus** 8x the volumetric capacity of the haulage connecting the ends to the RAW.

NOTE:

If, at any stage, blasting fumes from any end being multi-blasted contaminates any working places in the vicinity then multi-blasting must cease and conventional time blasting, or fixed-time blasting, must be done until conditions have been rectified for multi-blasting.

8. CALCULATION OF THE RE-ENTRY INTERVAL FOR SEQUENTIALLY VENTILATED DEVELOPMENT ENDS

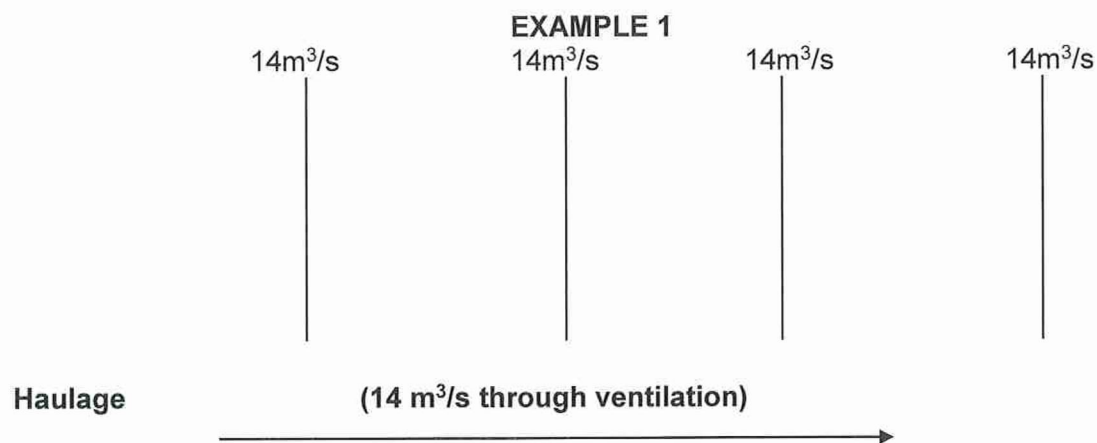

Assumptions:

1. All ends are at maximum length (180m)
2. Spacing of ends: 120m apart

Prevention of flammable gas and coal dust explosions in mines other than coal mines

3. No ventilation column leakage
4. $14\text{m}^3/\text{s}$ force ventilation per end (Q_F)

Re-entry per end, including the time taken to clear the haulage to the next end, per 8 air changes:

<u>End</u>		<u>Haulage</u>		
$= \frac{l \times w \times h \times 8}{(Q_F) \times 60}$	+	$\frac{l \times w \times h \times 8}{(Q_F) \times 60}$		
$= \frac{180 \times 4 \times 4 \times 8}{14 \times 60}$	+	$\frac{120 \times 4 \times 4 \times 8}{14 \times 60}$		
= 27,4	+	18,3 minutes		
= 45,7 minutes, Say 46 minutes				

Re-entry to the last end (no haulage to clear) = 27,4 minutes

Total re-entry, based on 8 air changes = $(46 \times 3) + 27,4$
 = 165,4 minutes. **Say 165 minutes**

Re-entry interval to this section after the general blast = $2\frac{3}{4}$ hours

EXAMPLE 2

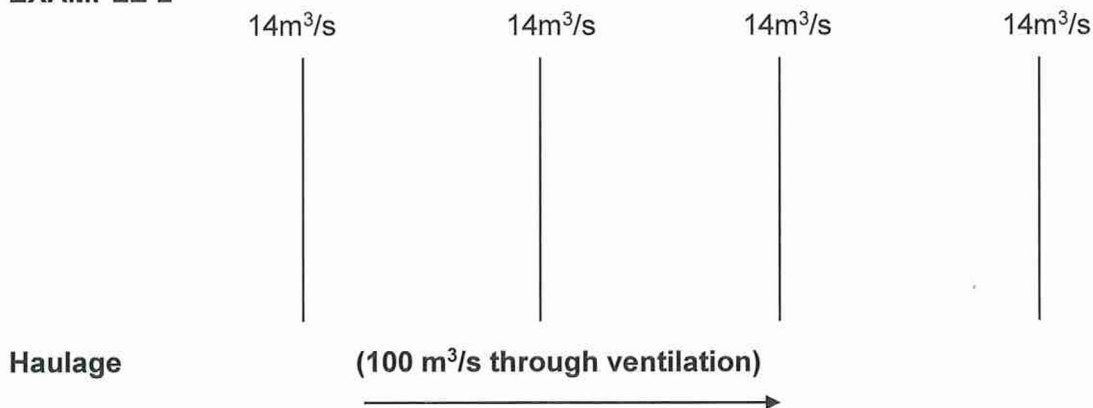

Assumptions:

5. All ends are at maximum length (180m)
6. Spacing of ends: 120m apart
7. No ventilation column leakage
8. $14\text{m}^3/\text{s}$ force ventilation per end (Q_F)

Prevention of flammable gas and coal dust explosions in mines other than coal mines

Re-entry per individual end, including the time taken to clear the haulage to the next end, per 8 air changes:

End		Haulage		
$= \frac{l \times w \times h \times 8}{(Q_F) \times 60}$	+	$\frac{l \times w \times h \times 8}{(Q_F) \times 60}$		
$= \frac{180 \times 4 \times 4 \times 8}{14 \times 60}$	+	$\frac{120 \times 4 \times 4 \times 8}{100 \times 60}$		
= 27,4	+	2,6 minutes		
= 30 minutes				

Re-entry to the last end (no haulage to clear) = 27,4 minutes

Total re-entry, based on 8 air changes: = (30 x 3) + 27.4

= 117,4 minutes. **Say 120 minutes.**

Re- entry interval to this section after the general blast = 2 hours

9. ADVANTAGES AND DISADVANTAGES OF FORCED AND EXHAUST OVERLAP SYSTEMS

9.1 Advantages of forced column system when multi-blasting

- 9.1.1 Good quality air is delivered to the face at high velocity where the workers derive maximum benefit.
- 9.1.2 Only a single fan and single column are required.
- 9.1.3 The fan and fan motor are always in fresh air.
- 9.1.4 Leakage is always from the column and hence easily detected.

9.2 Disadvantages of forced column system when multi-blasting

- 9.2.1 Persons travelling and working in the drive do so in return air.
- 9.2.2 Long re-entry periods after the blast are necessary, hence rendering this system unsuitable for multi-blast development
- 9.2.3 Fumes from the blast are returned to the general mine air circuit.

9.3 Advantages of exhaust overlap system when multi-blasting

- 9.3.1 Rapid clearance of blasting fumes permits short re-entry period.

Prevention of flammable gas and coal dust explosions in mines other than coal mines

9.3.2 Persons travelling and working in the drive do so in fresh air as the return air is exhausted via the main column.

9.3.3 Blasting fumes are exhausted directly to return.

9.4 Disadvantages of exhaust overlap system when multi-blasting

9.4.1 The quality of air supplied to the face is inferior to that supplied by the forcing system. The slow-moving intake air along the drive can pick up heat, dust and gases in transit to the face.

9.4.2 Two columns and two fans are required.

9.4.3 Poor conditions can exist in the overlap section.

NOTE:

- (a) Fans in the exhaust column must be positioned in such a manner that the exhaust column remains under negative pressure, thus ensuring that no exhaust fumes leak back into the intake air flowing to the face.
- (b) The exhaust fans, which are the primary source of **through ventilation**, should be interlocked with all other electrical appliances and equipment in the end being multiblasted. This is to ensure that, in the event of the exhaust fans stopping, all other electrical appliances and equipment will also shut down.
- (c) No butterfly valves must be positioned in any exhaust column.
- (d) To prevent open-circuit exhaust fans from recirculating a volume of at least $0,4\text{m}^3/\text{s}/\text{m}^2$ of **through ventilation**, at such fan sites, must be maintained at all times.

REFERENCES

- Environmental Engineering in SA Mines – Mine Ventilation Society of South Africa, pp 279 – 283
- Mine Ventilation Practitioner's DATA BOOK - Mine Ventilation Society of South Africa, pp UV-DE 2 to UV-DE 7

Prevention of flammable gas and coal dust explosions in mines other than coal mines

ANNEXURE 4: Construction requirements for a fire seal

CONSTRUCTION REQUIREMENTS FOR A FIRE SEAL

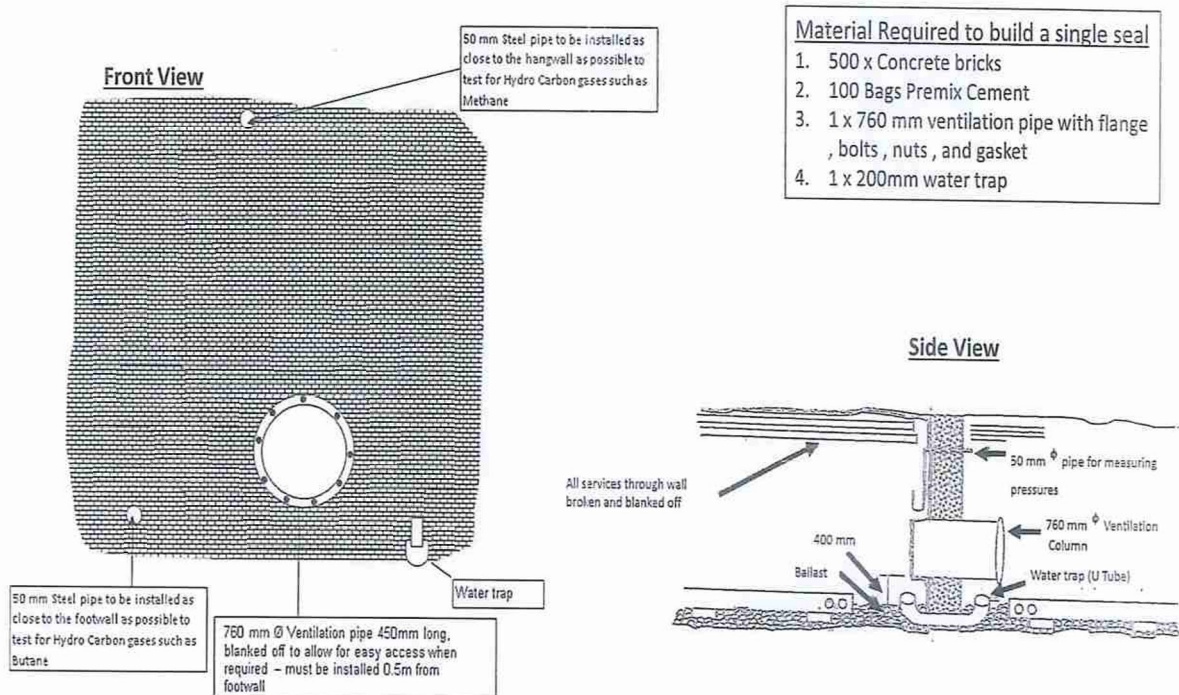

Prevention of flammable gas and coal dust explosions in mines other than coal mines

ANNEXURE 5: References
(For information purposes only)

Cook AP - "GAP 504". - The Occurrence, Emission and Ignition of Combustible Strata Gases in Witwatersrand Gold Mines and Bushveld Platinum Mines, and Means of Ameliorating Related Ignition and Explosion Hazards, 1999.

The Mine Ventilation Society of South Africa - "Environmental Engineering in South African Mines".

"Mine Health and Safety Act" - Act No. 29 of 1996 as amended

DMR "Lamprooms guidance note"

DMR "Emergency preparedness guideline"

SANS documents 10108, I0086 -1 and 2 ARP 0108 SANS 1515-1 and 2 etc. to be included.

SANS 10108:2003 The classification of **hazardous locations** and selection of equipment to be used in such locations.

SANS 100086-1: 2011 The installation, inspection and maintenance of equipment used in explosive atmospheres, Part 1 installations including surface installation on the mine.

SANS 100086-2: 2011 The installation, inspection and maintenance of equipment used in explosive atmospheres.

ARPO 108:2013 Regulatory requirements for explosive provided apparatus.

SANS 1515-1:2006 (Battery operated portable **flammable gas** measuring instruments and warning sensor head) gas measuring equipment primarily used in mines.

SANS 1515-2:2006 Fixed (transport and vehicle mounted **flammable gas** measuring and warning sensor heads) gas measuring equipment primarily used in mines and the ARP 0108 -2013-Regulatory requirements for explosive prevention.

DEPARTMENT OF MINERAL RESOURCES AND ENERGY

NO. 327

9 April 2021

MINE HEALTH AND SAFETY ACT, 1996 (ACT NO 29 OF 1996)

GUIDANCE NOTE ON THE MANAGEMENT AND CONTROL OF HIV IN THE SOUTH
AFRICAN MINING INDUSTRY

I, **DAVID MSIZA**, Chief Inspector of Mines, under section 49(6) of the Mine Health and Safety Act, 1996 (Act No. 29 of 1996) and after consultation with the Council, hereby issues the guidance note on the management and control of HIV in the South African mining industry in terms of the Mine Health and Safety Act, as set out in the Schedule.



D MSIZA
CHIEF INSPECTOR OF MINES

SCHEDULE

Management and control of HIV in the mining industry

Reference Number: DMR 16/3/2/3-B3
Last Revision Date: First edition
Date First Issued: First edition
Effective Date: 01 May 2021

DEPARTMENT OF MINERAL RESOURCES AND ENERGY

MINE HEALTH AND SAFETY INSPECTORATE

GUIDANCE NOTE ON

**MANAGEMENT AND CONTROL OF HIV IN THE
SOUTH AFRICAN MINING INDUSTRY**



CHIEF INSPECTOR OF MINES



**mineral resources
& energy**

Department
Mineral Resources and Energy
REPUBLIC OF SOUTH AFRICA

Management and control of HIV in the mining industry

CONTENTS

PART A: THE GUIDANCE NOTE	3
1. FOREWORD	3
2. SCOPE	3
3. STATUS OF THE GUIDANCE NOTE	4
4. THE OBJECTIVES OF THE GUIDANCE NOTE	4
5. DEFINITIONS AND ACRONYMS	5
6. MEMBERS OF THE TASK TEAM	6
7. THE OBJECTIVES OF THE HIV AND AIDS MANAGEMENT PROGRAMME AT A MINE	6
8. ASPECTS TO BE ADDRESSED IN THE GUIDANCE NOTE	7
8.1. HIV policy development and implementation	7
8.2. HIV programme	7
9. INTEGRATION OF HIV AND TB MANAGEMENT	9
10. FITNESS TO PERFORM WORK	9
11. PACKAGE OF HIV MANAGEMENT	10
12. MONITORING AND REPORTING	11
13. TRAINING AND SUPPORT	11
14. LIAISON WITH THE PUBLIC SECTOR	12
15. CERTAIN DOCUMENTS TO BE AVAILABLE	12
16. PROGRAMME PERFORMANCE MONITORING AND EVALUATION	12
PART B: IMPLEMENTATION	13
1. IMPLEMENTATION PLAN	13
2. COMPLIANCE WITH THE GUIDANCE NOTE	13
3. ACCESS TO THE GUIDANCE NOTE AND RELATED DOCUMENTS	13
REFERENCES	14

Management and control of HIV in the mining industry

PART A: THE GUIDANCE NOTE

1. FOREWORD

- 1.1. This guidance note has been produced to assist in the management and control of **HIV** in the South African mining industry. It is intended as a supplement to the **NTBMG** and **NSP** issued by the of **NDOH** and the **SANAC** respectively. It also reinforces the need for continuous social dialogue amongst stakeholders. It embraces the ten key principles of the **ILO COP** on **HIV/AIDS** and the world of work. The mining industry has assumed a more active role to address the problem of **HIV** and **AIDS**.
- 1.2. At the 2011 Mine Health and Safety Summit a commitment was signed off by all Tripartite Principals to report on **HIV** programme within the South African mining industry. It was enforced by an Instruction number OH/02/2013 from the Chief Inspector of Mines to report on **HIV** and **TB** management. The DMR 164 Form was developed as a reporting tool on **HIV** and **TB** for the mining industry.
- 1.3. The following risk factors are associated with the epidemic of **HIV** and **AIDS** in the mines: migrant labour system, hostel accommodation, alcohol abuse, sex workers (trucking), informal settlements around the peri-mining communities and risky sexual behaviour. However, this document does not specifically address the management of these risks.
- 1.4. **HIV** and **AIDS** is associated with a decrease in immunity resulting in opportunistic infections. Therefore, the integration of **TB** and **HIV** management and control programme is essential. Since **HIV** and **AIDS** is a workplace issue that affects the workforce and world of work, the workplace can play a vital role in limiting the spread and effects of the epidemic. All employees (permanent and contract) including management should be involved in all aspects of programme co-ordination, implementation and reporting.
- 1.5. People Living with **HIV** and **AIDS** have the same human rights as the rest of the uninfected population. The programme should provide an integrated **HIV** prevention, **HIV** Testing, **TB** and **NCD** services, and linkage to treatment and care to reduce stigma and discrimination.
- 1.6. An integrated **HIV** and **TB** programme should include **NCD** services, and linkage to treatment and care to reduce stigma and discrimination. Gender equality in the form of relations and empowerment of women should be actively addressed. The principle of confidentiality should not be compromised.

2. SCOPE

- 2.1. The practice standards set out in this document should apply to all mine workers, irrespective of employment category, and including contract workers.
- 2.2. The implementation of this Guidance Note is informed by the **NDOH HIV** and **AIDS** Management Guidelines and supported by relevant documents issued by the **DMRE**.
- 2.3. This guidance note should be implemented, *inter alia*, in conjunction with the following documents:

Management and control of HIV in the mining industry

- 2.3.1. Guidelines for tuberculosis preventive therapy among people living with **HIV** and silicosis in South Africa (**IPT** policy).
- 2.3.2. Compendium of **TB** leading practices in the South African mining industry.
- 2.3.3. Policy on the integrated management and reporting for **HIV/AIDS**, **TB** and Occupational Lung Diseases in the South African mining industry.
- 2.3.4. Guidance Note for the management of **TB** in the South African mining industry.
- 2.3.5. South African mining industry strategy on reducing **TB** and **HIV**.
- 2.3.6. Guidance note for the implementation of **HIV** self-testing in the South African mining industry.
- 2.3.7. Guidance note on strengthening **HCT** (**HIV** Counselling and Testing) uptake in the South African mining industry.

3. STATUS OF THE GUIDANCE NOTE

- 3.1. This guidance note sets out **good practice** on the management and control of **HIV** in the mining industry and will be distributed by the Mine Health and Safety Inspectorate.
- 3.2. As is the case with all other documents setting out accepted **good practice** through linking employees to **HTS** and observing the industry milestones targets and the UNAIDS 90/90/90 targets. The application of inferior practices without justification could be regarded as negligence.

4. THE OBJECTIVES OF THE GUIDANCE NOTE

- 4.1. The objectives of this guidance note are to assist employers to establish sustainable **HIV** and **AIDS** management and control programmes at mines to:
 - 4.1.1. Implement prevention strategies.
 - 4.1.2. Reduce the burden of **HIV**.
 - 4.1.3. Improve clinical outcomes of people living with **HIV**.
 - 4.1.4. Reduce morbidity due to **HIV** and **TB** co-infection.
 - 4.1.5. Reduce **HIV** incidence (reduce the number of new infections amongst employees and their families).
 - 4.1.6. Avert **AIDS** related deaths ensuring that people living with **HIV** start with the right therapy at the right time.
- 4.2. Ensure compliance to obligations as prescribed in other relevant labour legislation (LRA, EEA, BCEA) and other relevant **COPs**.

Management and control of HIV in the mining industry

5. DEFINITIONS AND ACRONYMS

- “**AIDS**” means acquired immunodeficiency syndrome.
- “**ART**” means anti-retroviral treatment.
- “**COIDA**” means Compensation for Occupational Injuries and Disease Act (Act 130 of 1993).
- “**COP**” means Code of Practice.
- “**DHIS**” means District Health Information System.
- “**DMRE**” means Department of Mineral Resources and Energy.
- “**EAP**” means an employee assistance programme.
- “**ELISA**” means enzyme-linked immunosorbent assay.
- “**Good practice**” as used in this document means linking employees to **HTS** and observing the industry milestones targets and the UNAIDS 90/90/90 targets.
- “**HAST**” means **HIV, AIDS, STI** and **TB**.
- “**HB**” means haemoglobin.
- “**HCT**” means **HIV** counselling and testing.
- “**Health worker**” means all people primarily engaged to enhance health by providing preventative, curative, promotional or rehabilitative health care services.
- “**HIV**” means human immunodeficiency virus.
- “**HTS**” means **HIV** testing services.
- “**ILO**” means International Labour Organisation.
- “**IPT**” means isoniazid preventive therapy.
- “**IRIS**” means immune reconstitution inflammatory syndrome.
- “**LDL**” means low density lipoprotein cholesterol.
- “**MBOD**” means Medical Bureau for Occupational Diseases.
- “**MCB**” means master cell bank.
- “**MCV**” means mean corpuscular volume.
- “**MHSA**” means Mine Health and Safety Act, (Act No 29 of 1996), as amended.
- “**MHSC**” means Mine Health and Safety Council.

Management and control of HIV in the mining industry

- “**NCD**” means non-communicable diseases.
- “**NDOH**” means National Department of Health.
- “**NIMART**” means nurse-initiated management of **ART**.
- “**NIOH**” means National Institute for Occupational Health.
- “**NSP**” means National Strategic Plan for **HIV, TB** and **STIs** 2017 - 2022.
- “**NTBMG**” means National Tuberculosis Management Guideline issued by **NDOH**.
- “**PEP**” means post exposure prophylaxis.
- “**PrEP**” means pre-exposure prophylaxis.
- “**SANAC**” means South African National **AIDS** Council Trust.
- “**STI**” means sexually transmitted diseases.
- “**TB**” means tuberculosis.

6. MEMBERS OF THE TASK TEAM

This guidance note was prepared by members of the task team, which comprised of:

State

Dr L. Ndelu
Dr D. Mokoboto
Mr M. Sekoele
Mr R. Sinthumule

Organised Labour

Mr C. Mkhumane

Employers

Ms S. Ntimbane
Dr I. Mampa

7. THE OBJECTIVES OF THE HIV AND AIDS MANAGEMENT PROGRAMME AT A MINE

- 7.1. Obtain 100% screening of all employees for **HIV**.
- 7.2. Ensure that 90% of confirmed **HIV** positive employees are initiated on **ART**.
- 7.3. Achieve a defaulter rate of less than 5% on **ART** (in line with **HIV** Clinicians Society Guidelines and the State guidelines).
- 7.4. Achieve 90% viral suppression by conducting a six-monthly monitoring and assessment of response to treatment.

Management and control of HIV in the mining industry

7.5. Reduce opportunistic infections mainly **TB** (integration of **HIV** and **TB** management).

7.6. Screen and refer for treatment of **NCDs** e.g. diabetes and hypertension.

7.7. Ensure continuity of care of employees with **HIV and AIDS**.

7.8. Report all **HIV** and **AIDS** cases to the **DMRE** as per DMR 164 form.

8. ASPECTS TO BE ADDRESSED IN THE GUIDANCE NOTE

The elements or components should, amongst others, cover the following:

8.1. HIV Policy development and implementation

Respect for human rights is a non-negotiable principle of the **NSP**. Adherence to this principle also enhances the effectiveness of prevention and treatment. The **NSP** focuses on equal treatment for all, increased access to justice, and the reduction of stigma associated with **HIV** and **TB**.

8.1.1. The policy should address, but not limited to:

- a) Stigmatisation
- b) Non-discrimination
- c) Confidentiality

8.2. HIV Programmes

8.2.1. Prevention:

- a) Information, education and mass mobilisation.
- b) Sexual transmitted infection detection and management.
- c) Distribution of male and female condoms.
- d) Promote **HCT**:
 - (i) **HCT** campaigns should be held bi-annually (consider annually as minimum standards).
 - (ii) The employer should ensure that voluntary **HCT** is offered to all employees at all health contact points.
- e) Screening and referral for voluntary male medical circumcision.
- f) Screening and referral for **PrEP** and **PEP**.
- g) Strengthening of **TB** prevention through **IPT** roll-out in **HIV** positive individuals and those that are on **ART**.
- h) Universal precautions for healthcare workers.

Management and control of HIV in the mining industry

8.2.2. Treatment, care and support

- a) Access to treatment, care and support.
- b) Treatment should be instituted in line with the National **HIV** testing guidelines and test and treat policy.
- c) The programme should serve to ensure **HTS** are integrated and linked effectively to all **HIV** prevention, treatment and care as well as other non-**HIV** health services (**TB**, **NCDs**) to reduce stigma and discrimination.

8.2.3. Clinical outcomes of people living with **HIV**

- a) Provide 100% **HIV** counselling to all employees.
- b) 90% of all people living with **HIV** will know their **HIV** status.
- c) 90% of all people with an **HIV** diagnosis will receive sustained antiretroviral therapy.
- d) 90% of all people receiving antiretroviral therapy will achieve viral suppression.
- e) Ensure that 90% of confirmed **HIV** positive employees are linked to healthcare services and initiated on **ART**.
- f) Laboratory confirmation of **HIV** positive screening test with **ELISA** 4th generation confirmation blood test.

NOTE:

All employees should be inducted on **HIV** and encouraged to test.
Employees who consent to testing should undergo voluntary counselling and testing for **HIV**.
Pre- and post-**HIV** test counselling must be performed for assisted or non-assisted screening testing done initially with a screening Abbots test or self-screening test.
An employee with a positive result must be referred to the clinic or General Practitioner for a laboratory confirmation test of **HIV** with an **ELISA** 4th generation test or as per the latest **NDOH** testing guidelines.

8.2.4. Achieve 90% viral suppression

- a) Viral monitoring should be done at initiation of treatment.
- b) Follow-up at 24 weeks to ensure compliance and adherence to treatment.
- c) Follow-up at 52 weeks to ensure viral suppression.
- d) Monitor achieved viral suppression annually.

8.2.5. CD4 count monitoring to assess immunological response to treatment

- a) CD4 count should be done at initiation of treatment.

Management and control of HIV in the mining industry

- b) Follow-up at 24 weeks to ensure compliance to treatment. If on assessment of the CD4 count there is deterioration or a decrease in the CD4 count versus the initial count and the viral load remains undetectable <50copies, log <1.60 the employee must be referred to the clinic or General Practitioner to exclude the presence of opportunistic infections e.g. **TB** or lymphoma.
- c) Monitor CD4 count annually to ensure immunological response to treatment.

8.2.6. Achieve a defaulter rate of less than 5% on **ART**

- a) Promote treatment adherence through counselling, peer supporter programme, **EAP**, etc.
- b) Ensure continuity of care of all employees through monitoring and treatment.
- c) Implement an effective defaulter management mechanism (knowing the disease profile and collecting data on viral loads and CD4 counts).
- d) Collect pertinent information or statistical data for evaluation purposes in readiness for completion of DMR 164 form and other required legislated forms.

9. **INTEGRATION OF HIV AND TB MANAGEMENT**

- 9.1. Before initiation on **ART**, screen for **TB** (cough questionnaire) as a baseline. Initial assessment of full blood count, **HB** and **MCV** to exclude anaemia of chronic disorders which might indicate the presence of/either opportunistic diseases e.g. **TB**, lymphoma etc. Refer for monitoring of FBC bi-annually.
- 9.2. All employees with presumptive symptoms to have a chest X-ray, gene Xpert, or a smear to exclude **TB**.
- 9.3. Those diagnosed with **TB** to be initiated on treatment for two weeks before **ART** initiation, to prevent **IRIS**.
- 9.4. Those without active **TB**, initiate or refer for **ART** treatment and isoniazid prophylaxis.
- 9.5. Employees diagnosed with **NCD** (e.g. diabetes and hypertension), monitor for drug-drug interactions whilst on **ART** treatment especially on FDC regimen containing Tenofovir. Monitor urea, creatinine and GFR for patients on Tenofovir at initiation of treatment and six-monthly.
- 9.6. Monitor drug-drug interaction whilst on **ART**.
- 9.7. Hypercholesterolemia - monitor **LDL** at initiation of treatment and follow-up yearly.
- 9.8. Isoniazid prophylaxis of all employees diagnosed with silicosis and **HIV** and **AIDS** including those on **ART**.

10. **FITNESS TO PERFORM WORK**

Evaluation of fitness to return to work should be individualised and must not preclude an employee from work based on their **HIV** status, CD4 count and viral load. The

Management and control of HIV in the mining industry

decision of fitness to work should be made on the grounds of a medical assessment in line with the company's Mandatory **COP** on minimum standards of fitness to perform work at a mine.

11. PACKAGE OF HIV MANAGEMENT

11.1. A holistic package of **HIV** management care should inter alia, include:

- a) **HTS**.
- b) Adherence counselling.
- c) Psychological support.
- d) Nutritional assessment and education.
- e) Integration with the **TB** prevention and management programme.

11.2. A treatment adherence programme should be implemented for all **HIV** cases.

The programme should cover the following:

- a) Education about the disease.
- b) Lifelong treatment.
- c) Medication to be taken and possible side effects.
- d) Importance of adherence to prescribed treatment regime.
- e) Available psychosocial support.
- f) Treatment support and monitoring.
- g) Viral suppression monitoring.
- h) Lifestyle modification.
- i) Loss to follow-up in **HIV** patients whilst in employment.
- j) Referrals (where there are no in-house services).

11.3. Continuity of **HIV** care beyond employment

- a) Where a patient's employment is terminated while on **ART**, the patient should be referred to an appropriate **HIV** care facility where the patient can continue treatment.
- b) Explore options to implement the TIER.Net, cross border referral system through National **TB** Programme Managers, TEBA and other relevant service providers.

Management and control of HIV in the mining industry

- c) The patient should be provided with a letter or form (generated from the TIER.Net system) detailing the diagnosis, bacteriological investigations conducted (including dates), treatment regimen dosages, CD4 count and viral load trends on the monitoring tool and other chronic medication or ancillary medication that the patient is taking.
- d) If the existing employee has co-morbidity (**HIV** and **TB**) a letter should be provided indicating the expected date for follow up at the mine health centre/one stop services during and post treatment (12-months after treatment completion).
- e) The referral letter should be accompanied by:
 - i) GW 20/14 referral form prescribed by the **NDOH**.
 - ii) The patient's health record (green card).
 - iii) **MBOD** guideline/**COIDA** (first, progress and final report) for benefit examination and compensation.

11.4. The patient should be provided with a counselling package which includes:

- a) The available information on the receiving facility; and
- b) Importance of presenting to the receiving facility to his home and continuation and when they should present to the clinic/ hospital.

NOTE:

A copy of the GW 20/14 form should be forwarded to the province/country where the patient resides to ensure continuum of treatment and care.
The acknowledgement slip on the form must be completed by the receiving facility and returned to the referring mine health facility.

11.5. Where the employer does not provide access to health services, it should refer employees to the nearest local healthcare facility for diagnosis and treatment.

12. MONITORING AND REPORTING

The following monitoring and reporting initiatives should be addressed:

- a) The monthly report for the **DHIS** and quarterly report for the TIER.Net should be submitted to the district health authorities.
- b) Reporting should be made in terms of the Chief Inspector of Mines' Instruction, as per DMR 164 form.

13. TRAINING AND SUPPORT

The employer's **HIV** management and control programme should address the following training initiatives:

- a) **Health workers** should be specifically trained in all aspects of **HIV** management in accordance with the **NDOH NIMART** guidelines and the **DMRE** management and control of **HIV** in the South African mining industry guidance note.

Management and control of HIV in the mining industry

- b) All employees should be provided with an induction programme on prevention, transmission, signs and symptoms of **HIV** and the company's support services and the benefits of early detection and treatment.
- c) Data managers involved in the **HIV** control programme must be trained on the collection, recording, analysis and reporting of **HIV** data.

14. **LIAISON WITH THE PUBLIC SECTOR**

It is recommended that medical and nursing staff involved in the management of patients with **HIV** should on a regular basis interact with district health staff.

15. **CERTAIN DOCUMENTS TO BE AVAILABLE**

The employer should ensure that the following documents are available:

- a) Copies of the latest **NDOH HIV and AIDS** guidelines, **NIMART** and this guidance note should be available in all clinics and centres where **HIV** is treated.
- b) A copy of the employer's integrated **HIV** and **TB** policy should be available at the mine.
- c) The guidance note for the management of **TB** in the South African mining industry.

16. **PROGRAMME PERFORMANCE MONITORING AND EVALUATION**

- a) It is recommended that the internal monitoring and evaluation of the employer's **HIV** management and control programme should be conducted quarterly at the joint health and safety committee meetings.
- b) It is also recommended that an employer's **HIV** management and control programme be subjected to annual monitoring through the DMR 164 form.

Management and control of HIV in the mining industry

PART B: IMPLEMENTATION

1. IMPLEMENTATION PLAN

- 1.1 The employer must prepare an implementation plan for its guidance note for provision of issues such as organisational structures, responsibilities of functionaries and, programmes and schedules for the guidance note that will enable proper implementation of the guidance note. (A summary of and a reference to, a comprehensive implementation plan may be included).
- 1.2 Information may be graphically represented to facilitate easy interpretation of the data and to highlight trends for the purposes of risk assessment.

2. COMPLIANCE WITH THE GUIDANCE NOTE

The employer must institute measures for monitoring and ensuring compliance with the guidance note.

3. ACCESS TO THE GUIDANCE NOTE AND RELATED DOCUMENTS

- 3.1 The employer must ensure that a complete guidance note, and related documents are readily available at the mine for examination by any affected person.
- 3.2 A registered trade union with members at the mine or where there is no such union, a health and safety representative at the mine, or, if there is no health and safety representative, an employee representing the employees at the mine, must be provided with a copy of the written request to the manager. A register must be kept of such persons or institutions with copies to facilitate updating of such copies.
- 3.3 The employer must ensure that all employees are conversant with those sections of the guidance note relevant to their respective areas of responsibilities.

Management and control of HIV in the mining industry

REFERENCES

1. **NDOH HIV and AIDS** management guidelines.
2. National Strategic Plan for **HIV, TB** and **STIs** 2017 - 2022.
3. National **TB** guideline issued by **NDOH**.
4. Guidance note for the management of **TB** in the South African mining industry.
5. South African mining industry strategy on reducing **TB** and **HIV**.
6. Guidance note for the implementation of **HIV** self-testing in the South African mining industry.
7. Guidance note on strengthening **HCT** (**HIV** counselling and testing) uptake in the South African mining industry.
8. **ILO COP** on **HIV/AIDS** and the world of work.